



WAVE FORCE OF THE 1883 KRAKATAU TSUNAMI ON THE OUTER SEA DIKE IN JAKARTA BAY

GAYA GELOMBANG TSUNAMI KRAKATAU 1883 PADA TANGGUL LAUT LUAR DI TELUK JAKARTA

Eduardo Meyrianso Simanjuntak¹⁾ * Juventus Welly Radianta Ginting²⁾
Ida Ayu Irawati Diah Ratna Putra³⁾

¹⁾Program Studi Oseanografi, Fakultas Ilmu dan Teknologi Kebumihan, Institut Teknologi Bandung, Jalan Ganesha 10 Bandung, Jawa Barat, Indonesia

²⁾Balai Wilayah Sungai Sumatera II, Jl. Jenderal A.H Nasution No 30, Medan Johor, Medan, Sumatera Utara, Indonesia

³⁾Balai Teknik Pantai, Jl. Gilimanuk – Singaraja, Gerokgak, Buleleng, Bali, Indonesia

*Correspondent email: eduardodevescounte@yahoo.com

Diterima: 19 Agustus 2019; Direvisi: 10 September 2019; Disetujui: 27 November 2020

ABSTRACT

The increased volcanic activity of Mount Anak Krakatau has raised the awareness of the potential tsunami impact for the construction of National Capital Integrated Coastal Development (NCICD) Project. This research is aimed to evaluate the tsunami impact on the outer sea dike of NCICD. The 1883 Krakatau tsunami was used as reference to evaluate the coastal infrastructure. Time series data from the 1883 Krakatau tsunami is extracted as an input to calculate the wave force. There are three different methods used such as Rule of Thumb (wave force is twice that of hydrostatic force), Linear Theory, Sainflou method. The results show that the tsunami will hit the outer sea dike with at least force about 70 kN. The outer sea dike OSD-1A is the least impacted sea dike while OSD-3A is the most impacted. For OSD-1A, Rule of Thumb and Linear Theory estimate 303.30 kN of wave force while Sainflou method predicts only 73.45 kN. On the other hand, OSD-3A endured wave force of 131.91 kN (Sainflou method) or 531.91 kN (Rule of Thumb and Linear Theory). Sainflou method is for efficient design while the other methods have the benefit of safety factor.

Keywords: Sea dike, tsunami, wave force, NCICD, Krakatau

ABSTRAK

Meningkatnya aktivitas vulkanik Gunung Anak Krakatau telah membangkitkan kesadaran tentang potensi tsunami pada konstruksi National Capital Integrated Coastal Development (NCICD). Penelitian ini bertujuan untuk menghitung dampak potensial tsunami dalam bentuk gaya gelombang. Struktur pantai NCICD dievaluasi dengan gaya gelombang Tsunami Krakatau 1883 sebagai acuan evaluasi. Data time series Tsunami Krakatau 1883 diambil sebagai masukan perhitungan gaya gelombang. Ada beberapa metode yang digunakan seperti Rule of Thumb (gaya gelombang sama dengan dua kali gaya hidrostatik), Teori Linier dan metode Sainflou. Hasil penelitian menunjukkan bahwa tsunami menghantam tanggul laut minimal dengan kekuatan sekitar 70kN. Tanggul Laut OSD-1A mengalami dampak minimum sedangkan dampak maksimum terjadi pada OSD-3A. Untuk OSD-1A, Rule of Thumb dan Teori Linier memperkirakan gaya gelombang sebesar 303,30 kN sedangkan menurut metode Sainlou hanya sekitar 73,45 kN. Sebaliknya, OSD-3A mengalami gaya sebesar 131,91 kN (metode Sainflou) sedangkan 531,91 kN (Rule of Thumb dan Teori Linier). Metode Sainflou bermanfaat untuk desain yang efisien sedangkan metode yang lain unggul dalam faktor keamanan.

Kata Kunci: Tanggul laut, tsunami, gaya gelombang, NCICD, Krakatau

INTRODUCTION

Tsunami is a wave or series of waves in wave train generated by the sudden, vertical displacement a column of water (Bryant,2008). The term "Tsunami" is derived from Japanese words for "Harbour Wave" considering that this wave is usually observed in harbours. In the scientific community, the definition is widened to refer to a long wave with typical celerity of 200 m/s and wavelength of 1000 km which is more than the typical depth of the ocean, 4 km (Levin and Nosov,2009). In general, the discussion of tsunami can be classified into three main themes. First, the source of tsunami. The generating mechanism is usually discussed by scientists with earth science background such as geology, volcanology and geophysics. Their main endeavour is to determine whether the tsunami is generated by seismic, meteorological, cosmogenic or composite source. Second, the propagation of tsunami wave. This theme is the domain of oceanography discussing how the tsunami propagate from the source. This is important for the development of Early Warning System used in tsunami mitigation. The last theme is the effect of tsunami in coastal area. This can be in the form of coastal inundation, wave run-up and wave force. Coastal engineer is usually involved in this part of discussion either to design a sufficient coastal protection against tsunami or to evaluate the current coastal infrastructure against the potential impact of tsunami.

In recent years, the volcanic activities of Mount Anak Krakatau have increased significantly (The Jakarta Post,2018;2019). At the end of 2018, the volcanic activity of Mount Anak Krakatau generated Tsunami Sunda Strait. This volcanogenic tsunami caused the loss of life and massive damage (Setiawan, 2018; Tehusjarana, 2018). This heightens the sense of awareness about the latent danger from Mount Anak Krakatau. Historically, Mount Anak Krakatau emerged after Mount Krakatau erupted in 1883. The volcanic event also generated a series of tsunami. It is safe to assume that the magnitude of tsunami generated by the current Mount Anak Krakatau will not be greater than that of the 1883 Krakatau tsunami. In the other words, in the worst-case scenario, the tsunami generated by Mount Anak Krakatau will result in similar magnitude of the 1883 Krakatau tsunami in its maximum capacity. In this study, the effect of the 1883 Krakatau tsunami in the coastal area especially in Jakarta Bay will be discussed.

The complete account of the event of the 1883 Krakatau tsunami can be found in Verbeek

(1884), Symons (1888). In this event, series of explosions destroyed several mounts in the Krakatau Island subsequently. The explosion of Mount Poerbawatan and Mount Danan only caused minor tsunami while the last explosion of Mount Rakata generated in the biggest tsunami called Principal Tsunami. The source of this tsunami is debated among scientists. In general, a volcanogenic tsunami can be generated by ten possible sources (Latter,1981). Specific to the case of the 1883 Krakatau tsunami, there are four possible sources which are basal surges, pyroclastic flow, submarine explosion and caldera formation (Verbeek,1884; Francis,1985; Yokoyama,1981; Yokoyama,1987; Nomanbhoy and Satake ,1995; Latter,1981; Self and Rampino,1981). However, Maeno and Imamura (2011) show that pyroclastic flow is the most likely source while rejecting other hypothesis such as caldera formation, submarine explosion and lateral blast or basal surge. The propagation of this tsunami has been discussed extensively by Nakamura (1984), Choi et al. (2003) and Pelinovsky et al. (2005). According to the historical account of Verbeek (1984), the tsunami propagates to several coastal area including Jakarta Bay.

One of the concerns is that a potential tsunami from Mount Anak Krakatau will do significant damage to the coastal infrastructure in Jakarta Bay including the one developed in NCICD (National Capital Integrated Coastal Development) or PTPIN (*Pengembangan Terpadu Pesisir Ibukota Negara*) project. If a tsunami with magnitude of the 1883 Krakatau tsunami happened, it is still a question whether the sea dike of NCICD is able to withstand the adversity. According to Project Management Unit NCICD (2014), the objective of NCICD project is to provide an integrated solution for the protection of the coastal area of northern Jakarta from sea and river floods by developing an outer sea dike (OSD) with land reclamation and a fresh water retention lake. Thus, it remains essential to take the potential damage by tsunami into consideration of designing the NCICD sea dike. In the early phase of the project, there are six alternative designs of the sea dike. However, after the alternatives are analyzed using Multi Criteria Analysis (MCA), a preferred alternative is synthesized as shown in Figure 1. The discussion will focus not on the open sea dike or closed sea dike rather the position of the sea dike against the oblique tsunami propagation. The wave direction of the tsunami against the parallel line of the outer sea dike will determine the force which the wave acted on the structure.

The effect of the 1883 Krakatau tsunami in the term of run-up and water elevation has been discussed in the previous study by Simanjuntak et al. (2020) and Ginting et al. (2020) respectively. This study will focus on the wave force induced by the

1883 Krakatau tsunami and its effect on the outer sea dike segment (OSD) of NCICD (Figure 1). The aim is to evaluate the effect of tsunami wave on the outer sea dike of NCICD in terms of wave force.

According to USACE (1984), studies about wave force can be categorized into two themes: (1) by type of the structure and (2) by type of wave. The classification is summarized in Figure 2. In general, there are three types of coastal structures which wave force act on such as pile-supported structure (e.g piers and offshore platform), wall-type structure (such as sea dike, revetment, jetties and breakwaters) and rubble structure (e.g groins and jetties). On the other hand, the force acted on the structure can be induced by three different types of wave. First, non-breaking wave which typically happen in seaward of the surf zone. While sea

dike is built outside the surf zone, the incoming wave will not break but will be reflected instead by the surface of the wall. Standing wave or also known as clapotis will be generated and create wave force on the structure due to the pressure fluctuation. Second, breaking wave. This type of wave will generate wave force on the structure due to dynamic effects of turbulence force and compression of trapped air pocket (USACE,1984). The last type of wave is the broken wave which occur in shoreward of the surf zone. Computation of this wave-induced force is usually important for the safety of the building in the coastal area. Further reference can be found in Triatmadja and Nurhasanah (2012). In this study, the discussion will be focus on category 1W (force induced by non-breaking wave acting on sea wall-type structure). The tsunami wave of Krakatau 1883 is a non-breaking wave interacting with the outer sea dike of NCICD.



Figure 1 Preferred Alternative of the Outer Sea Dike NCICD Project: modified from (KOICA, 2018)

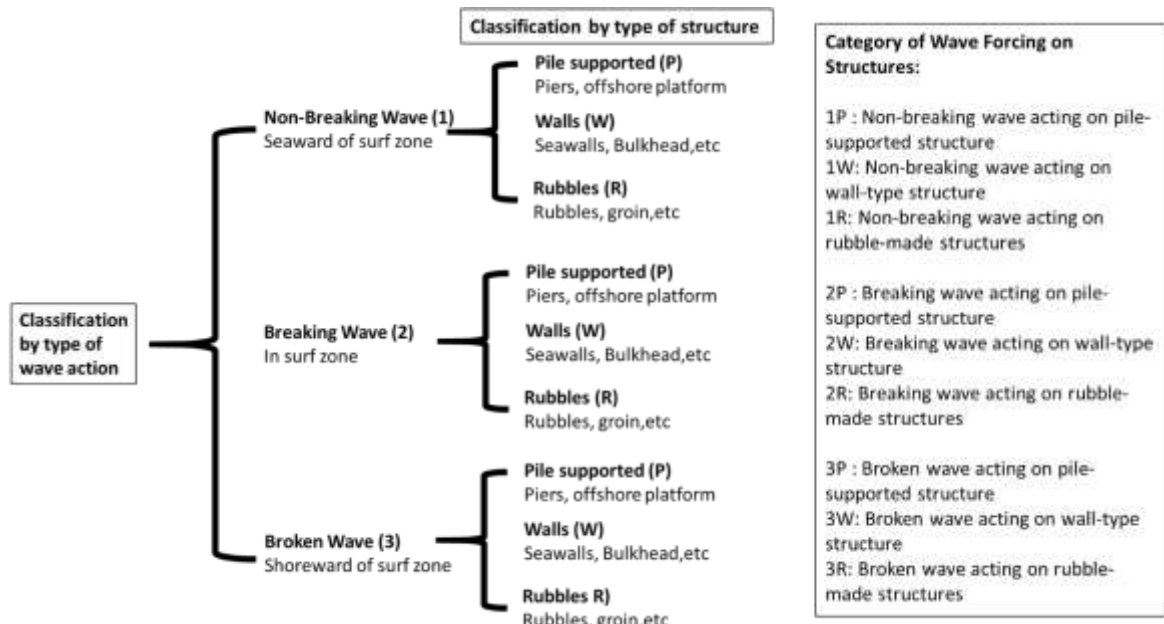

Figure 2 Classification of the study of wave force on coastal structure: modified from (USACE,1984)

METHODOLOGY

Pyroclastic flow mechanism is conclusively suggested by Maeno and Imamura (2011) as the source of the 1883 Krakatau tsunami. The rising water in the vicinity of the Krakatau Island is caused by the pyroclastic material flowing out of the Krakatau Mountain. The increased water elevation around the island, as shown in Figure 3, is used as an initial condition for tsunami simulation using hydrodynamic numerical model. The model is based on two governing equations which are

The continuity equation

$$\frac{\partial \zeta}{\partial t} + \frac{\partial u}{\partial x} + \frac{\partial v}{\partial y} = 0 \dots\dots\dots (1)$$

The momentum equation in x and t direction

$$\frac{\partial u}{\partial t} + \frac{\partial}{\partial x} \left(\frac{u^2}{h} \right) + \frac{\partial}{\partial y} \left(\frac{uv}{h} \right) + gh \frac{\partial \zeta}{\partial x} + \frac{gu\sqrt{u^2+v^2}}{c^2 \cdot h^2} = 0 \dots\dots\dots (2)$$

$$\frac{\partial v}{\partial t} + \frac{\partial}{\partial y} \left(\frac{v^2}{h} \right) + \frac{\partial}{\partial x} \left(\frac{uv}{h} \right) + gh \frac{\partial \zeta}{\partial y} + \frac{gv\sqrt{u^2+v^2}}{c^2 \cdot h^2} = 0 \dots\dots\dots (3)$$

where h (x,y,t) is water depth (m); ζ (x, y, t) is water elevation (m); u, v (x, y, t) is velocity in x dan y direction; c (x, y) is chezy resistance (m^{1/2}/s) and g is gravitational acceleration (m/s²).

The bathymetric input is from BATNAS (*Batimetri Nasional*) provided by *Badan Informasi Geospasial* (BIG). The model is defined in triangular mesh. There are five nesting grids in the model with higher resolution found in the coastal water of Jakarta Bay. Table 1 shows several important parameters for the model. Further discussion about the model and its verification can be found in the previous study by Ginting et al. (2020).

Water elevation time series of the tsunami is then extracted from the model in the vicinity of sea dike. This will be used to calculate the wave force on the structure. Figure 4 shows the position of outer sea dike in Jakarta Bay. This paper will discuss wave force acted on sea dike in cross section AA and cross section CC which are formally denoted as OSD-1 and OSD-3 respectively in KOICA report (2018). OSD-1 has slope of 1:7 and water depth for structure 15 m with reference to Low Water Spring (LWS). The planned height is 7.5 m above LWS. OSD-3 has the same planned height and water depth for structure but the slope is 1:3. Compared to OSD-3, the slope of OSD-1 is less steep since it is designed specifically to reduce overtopping and run up height. Therefore, the armor used in the sea dike is smaller in size but greater in quantity. On the other hand, OSD-3 has 1:3 slope which demands bigger armor. Hence, the volume of the material can be reduced. So, the benefit of the OSD-3 design is to reduce the construction cost. Figure 4 and Figure 5 shows detailed engineering design of both cross sections.



Figure 3 Increased water elevation induced by pyroclastic flow of Mount Krakatau: modified from Maeno and Imamura (2011)

Table 1 Numerical and physical model parameter

Max Element	$1,3 \times 10^8$	
Smallest Allowable	26	deg
Max Number of Nodes	2×10^5	
Number of Elements	120.236	
Number of Nodes	68.261	
Max Area Nesting Grid 1	$3,5 \times 10^6$	m^2
Max Area Nesting Grid 2	$8,5 \times 10^5$	m^2
Max Area Nesting Grid 3	$1,5 \times 10^5$	m^2
Max Area Nesting Grid 4	9×10^4	m^2
Max Area Nesting Grid 5	9.000	m^2
Number of Time Steps	43.200	
Time Steps Interval	0.5	s
CFL Number	0.8	
Flood/Dry/and Wetting Depths	0.005/0.05/.1	
Bed Resistance	32	$m^{1/3}/s$

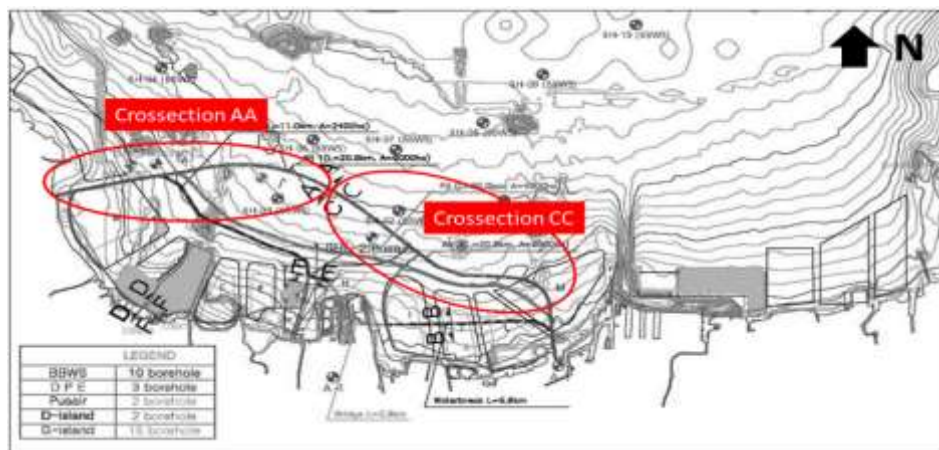

Figure 4 Sketch of the integrated coastal protection of NCICD (KOICA, 2018)

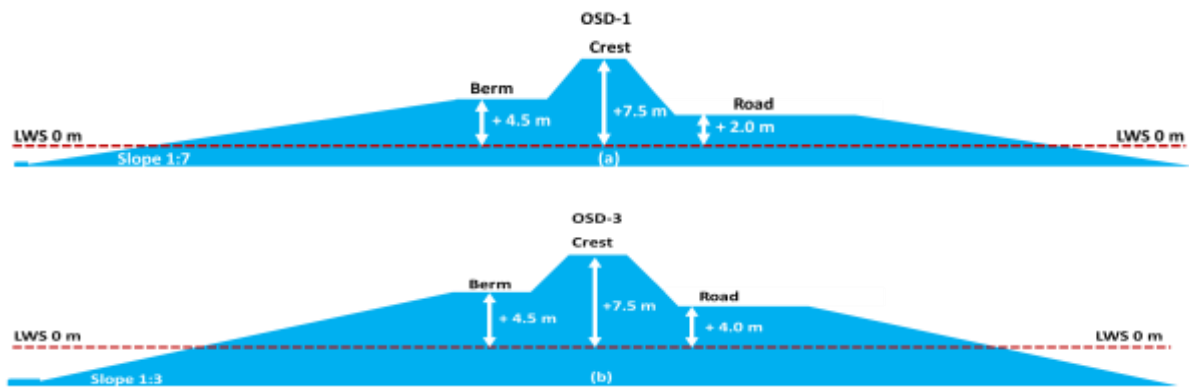

Figure 5 Sketch of outer seadike design: (a) OSD-1 (Crosssection AA); (b) OSD-3 (Crosssection CC)

Moleenaar and Voorendt (2016) summarize five different methods to calculate force acted by non-breaking wave on a wall-type structure. The five methods are Rule of Thumb, Sainflou Method, Rundgren Method, Goda Method and Linear Theory-based method. In this study, Rundgren and Goda method is not applied since it is more accurate for steeper wave. The other methods are suitable to estimate the force of less-steep wave such as tsunami on a wall-type coastal structure.

Rule of Thumb

In the case of sea dike, the assumption is that the incoming wave will be reflected completely. In other words, the wave height H in front of the structure is double the incoming wave height (H_i). In this paper, NCICD sea dike is assumed to have a total reflection for the calculation of wave force induced by the 1883 Krakatau tsunami. As simple rule of thumb, the maximum wave force F_{max} [N] acted on the wall is

$$F_{max} = 21\rho g H_i^2 + d\rho g H_i \dots \dots \dots (4)$$

in which:

- $\rho \left[\frac{kg}{m^3} \right]$ = density of water
- $g \left[\frac{m}{s^2} \right]$ = gravity acceleration
- H_i [m] = the wave height of an incoming wave
- d [m] = depth of breakwater

Linear Theory

This theory is based on linear wave theory which $H = 2H_i$ is valid. The force on the wall can be derived from the pressure distribution. The maximum pressure against a wall in case of reflection is

$$p = \rho g H_i \frac{\cosh \cosh (k(d+z))}{\cosh \cosh (kd)} \quad \text{for } d < z < 0 \dots \dots \dots (5)$$

$$p = \left(1 - \frac{z}{H_i} \right) \rho g H_i \quad \text{for } 0 < z < H_i \dots \dots \dots (6)$$

in which:
 k [m^{-1}] = the wave number of incoming wave ($= \frac{2\pi}{L}$)

After integration over water depth, the force per linear meter is

$$F = \rho g H_i \left(\frac{\exp(kd) - \exp(-kd)}{(kd)} + \frac{H_i}{2} \right) \dots \dots \dots (7)$$

In the case of tsunami which has a large wavelength, the wave pressure approaches the hydrostatic pressure. Figure 6 shows the pressure distribution on a wall based on linear theory.

Sainflou Method

This method is based on the second order theory of wave by Stokes (Sainflou,1928). When an incoming wave approaches, the still water level in front of structure will increase with

$$h_0 = \frac{1}{2} k H_i^2 \coth \coth (kd) \dots \dots \dots (8)$$

- where:
- h_0 [m] = increase of the still water level in front of wall
- d [m] = water depth in front of the sill

The maximum pressure at the still water level and near bed:

$$p_1 = \rho g (H_i + h_0) \dots \dots \dots (9)$$

$$p_0 = \frac{\rho g H_i}{\cosh \cosh (kd')} \dots \dots \dots (10)$$

where
 d' [m] = water depth above the foundation

Figure 7 shows the schematic description of the Sainflou method. The wave force can be calculated using integral of the area under the curve.

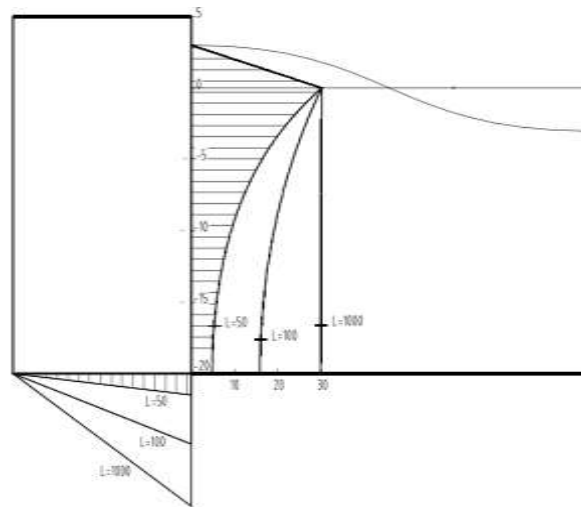

Figure 6 Wave pressure on a wall based on Linear Wave Theory (Molenaar and Voreendt, 2016)

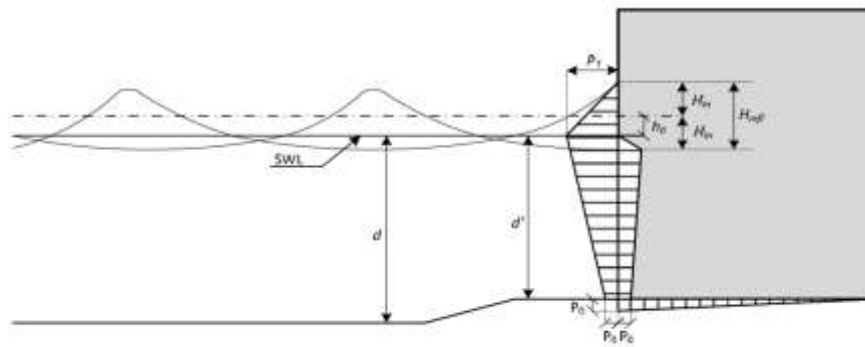

Figure 7 Wave pressure on a wall based on Sainflou Method (Molenaar and Voreendt, 2016)

RESULTS AND DISCUSSION

The numerical result shows how the tsunami interacts with the outer sea dike of NCICD. A detailed explanation has been given in previous study by Ginting et al. (2020). In general, the outer sea dike will respond the incoming wave by reflecting the wave. The result is a standing wave or also known as clapotis. The clapotis will increase the pressure on the wall twofold that of hydrostatic pressure especially for a long wave such as tsunami. On the other hand, the tsunami will give wave force on the structure. The magnitude of the force is determined by the angle between the wave and the outer sea dike. Figure 8 shows that the tsunami approaches the sea dike of OSD-1 nearly perpendicularly. This means that the wave force will be unleashed on the dike completely. For the other half of OSD-1 and OSD-3,

the wave propagates with oblique angle to the dike (Figure 9). The same case is in the rest of OSD-3 (Figure 10).

The tsunami will approach various segment of the outer sea dike differently. The wave will form certain angle with reference to the parallel of segment of outer sea dike of NCICD. Figure 11 give simple illustration of how the tsunami propagate obliquely to the sea dike. The dike will be classified into four segments based on type of cross section and the wave angle for the clarity of discussion. There are four segments which are OSD-1A, OSD-1B, OSD-3A and OSD-3B (Figure 12). The wave force on each segment will be calculated with the assumption that the force will be uniform horizontally for the whole part in the same segments.

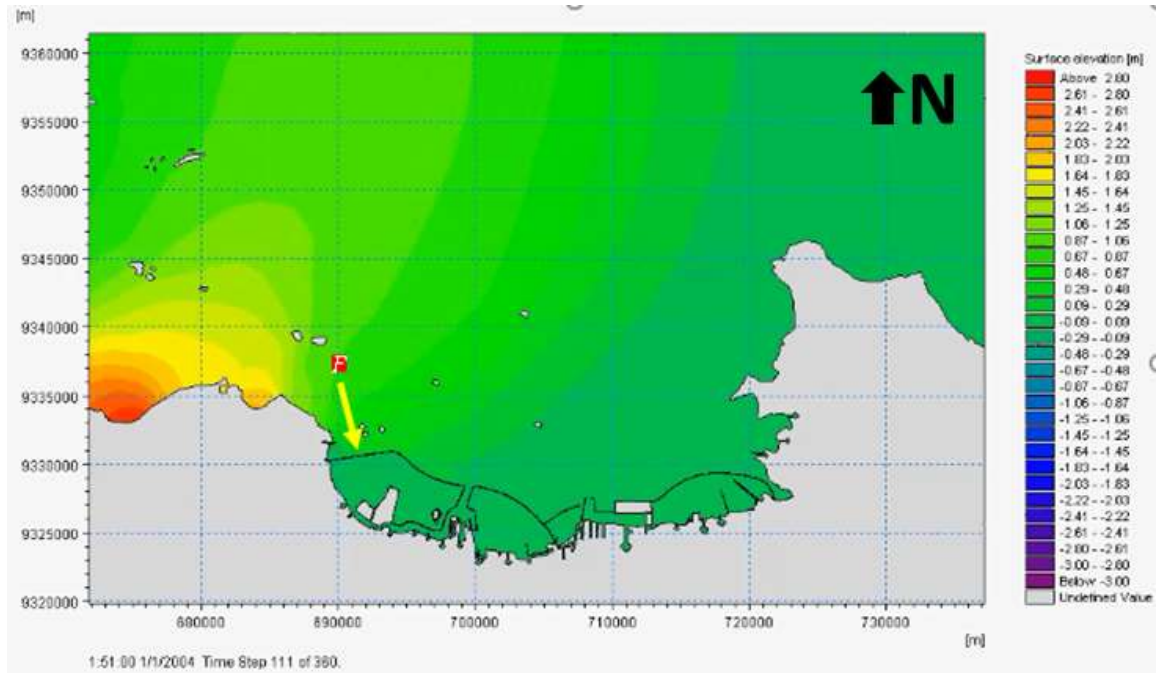

Figure 8 Wave approaches the outer sea dike OSD-1 with nearly right angle (Ginting et al.,2020)

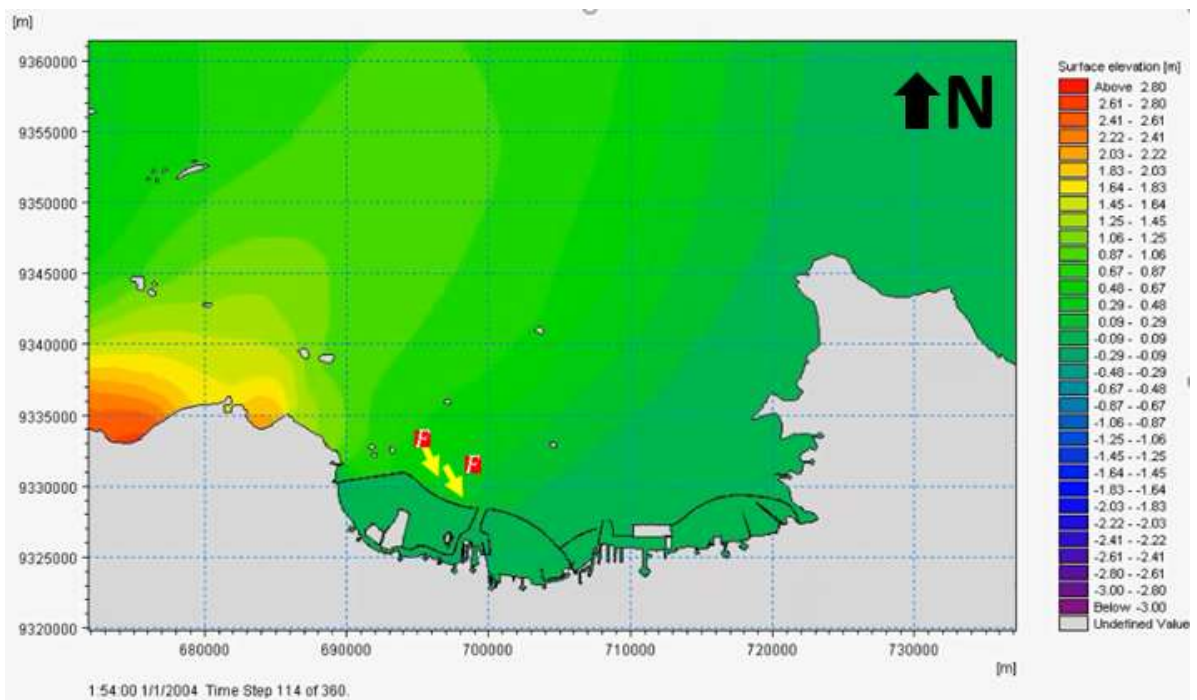

Figure 9 Wave approaches the outer sea dike OSD-1 and OSD-3 with certain angle (Ginting et al.,2020)

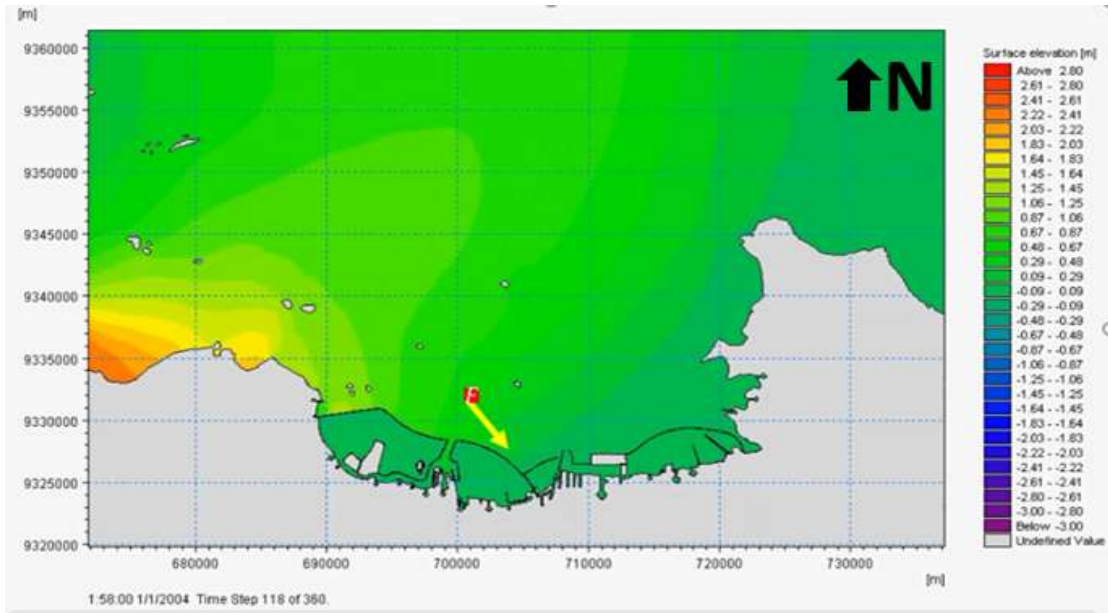

Figure 10 Wave approaches the outer sea dike OSD-3 with certain angle (Ginting et al.,2020)

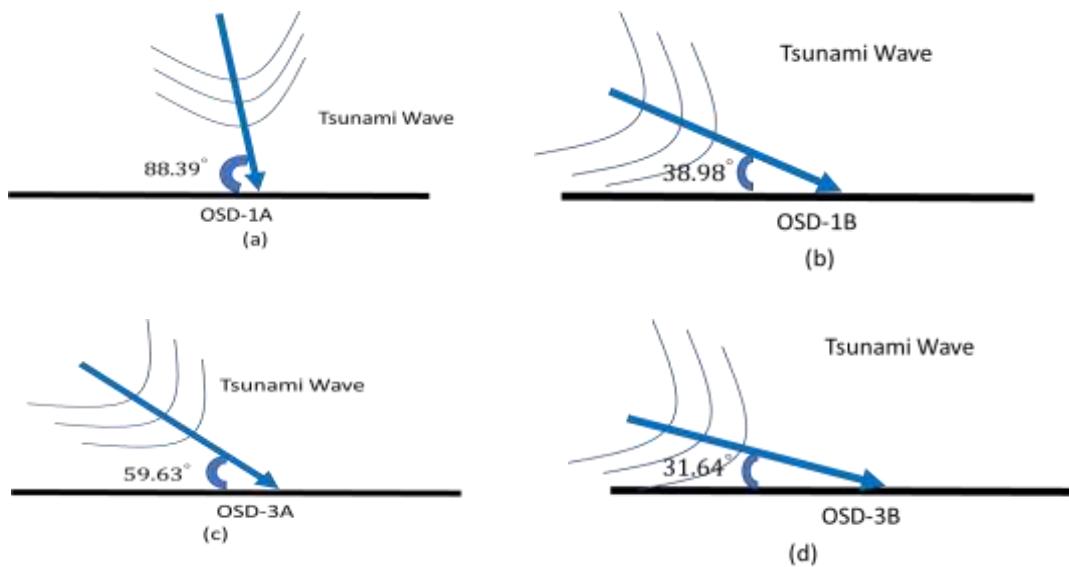

Figure 11 Tsunami wave approaches obliquely: (a) OSD-1A; (b) OSD-1B; (c) OSD-3A; (d) OSD-3B

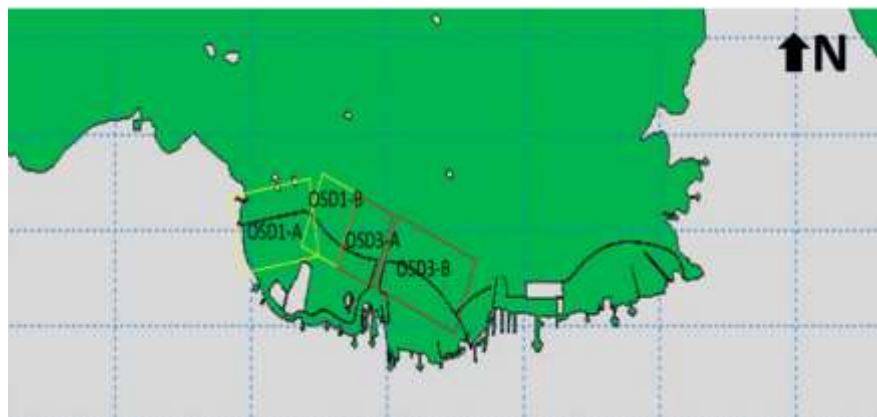

Figure 12 Outer Sea Dike Segment based on type of cross section and wave angle

The result of numerical model is defined with reference to Mean Sea Level (MSL). For the calculation of wave pressure and wave force, the reference level is Still Water Level (SWL). SWL is simply defined as the sea level with absence of the wind waves. Thus, since this model input is only from tsunami, the MSL can be assumed as the SWL. Another adjustment needs to be made is the reference level of the engineering design of the outer sea dike. The dike is designed with reference

to Low Water Spring (LWS). Figure 13 shows the tidal level in Jakarta Bay based on two different sea level reference. From this figure, there are 0.55 m between tidal level in MSL and LWS for the surface elevation 0 m. So,

$$LWS = MSL - 0.55 \dots\dots\dots (11)$$

With equation 12, the outer sea dike design can be adjusted to MSL as shown in Figure 14.

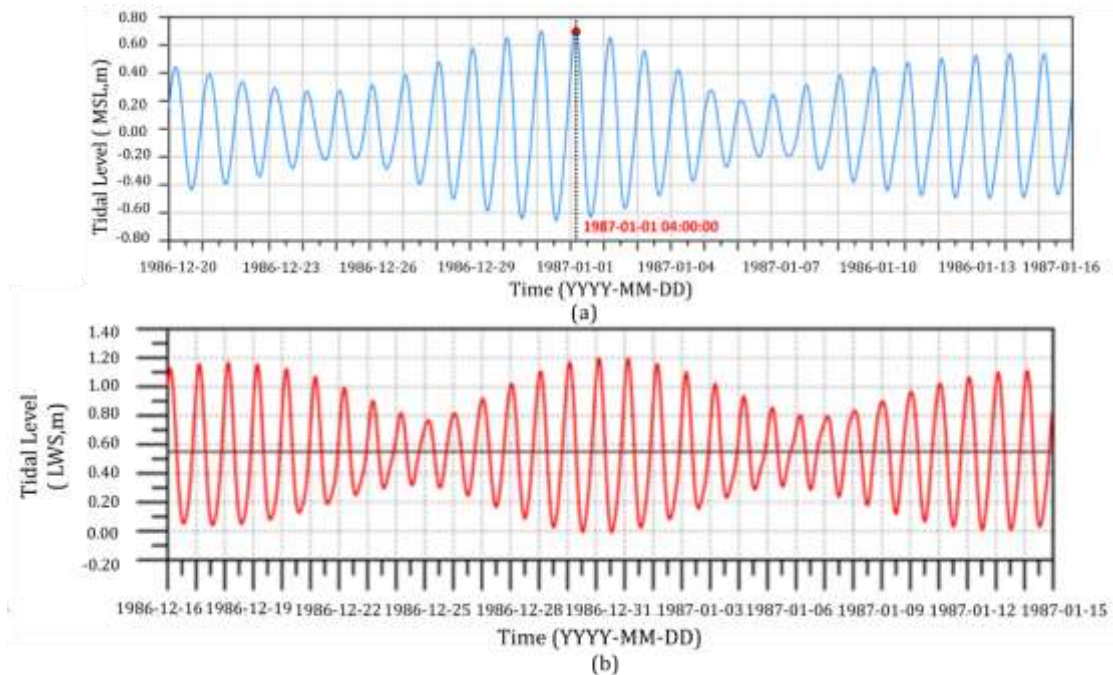

Figure 13 Tidal time series with reference to: (a) MSL and (b) LWS (KOICA, 2018)

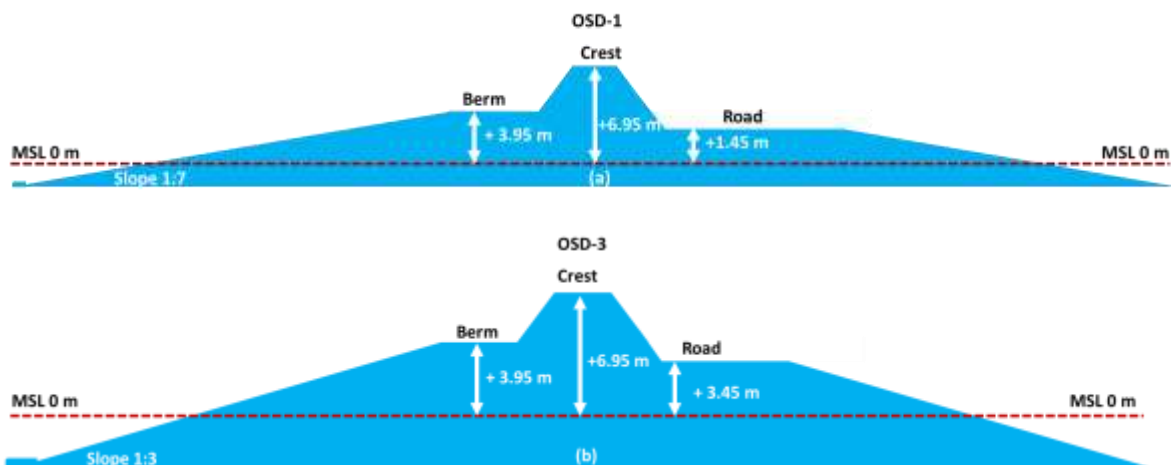

Figure 14 Outer Seadike after adjustment to MSL: (a) OSD-1 (Crossection AA); (b) OSD-3 (Crossection CC)

Rule of Thumb

Force induced by tsunami can be calculated for quick estimation using Rule of Thumb as stated in Equation 1. The incoming wave height (Hi) can be calculated from time series of tsunami water elevation. This time series data is extracted from numerical model which is already discussed in Ginting et al. (2020). The time series data can be viewed in Figure S1. The extracted point is 6 km away from the outer sea dike. Since the incoming wave interacts with outer sea dike, the wave will be reflected. Hence, the wave height will be double that of incoming wave. This is the wave input to Rule of Thumb. All relevant data and calculated force are shown in Table 2. The result shows that OSD-1A is hit by the weakest wave force within the order of 300 kN magnitude. On the other hand, the other segments of outer sea dike experienced twice the impact. This is because the water depth in front of OSD-1A is shallower while the other segments of sea dike is located in front of a deeper water.

Linear Theory

This theory is based on linear wave theory which $H = 2H_i$ is valid. The force on the wall can be derived from the pressure distribution. The maximum pressure against a wall in case of reflection is

$$p = \rho g H_i \frac{\cosh \cosh (k(d+z))}{\cosh \cosh (kd)} \quad \text{for } d < z < 0 \dots \dots \dots (5)$$

$$p = \left(1 - \frac{z}{H_i}\right) \rho g H_i \quad \text{for } 0 < z < H_i \dots \dots \dots (6)$$

in which:

$k [m^{-1}]$ = the wave number of incoming wave ($= \frac{2\pi}{L}$)

After integration over water depth, the force per linear meter is

$$F = \rho g H_i \left(\frac{\exp(kd) - \exp(-kd)}{(kd)} + \frac{H_i}{2} \right) \dots \dots \dots (7)$$

In the case of tsunami which has a large wavelength, the wave pressure approaches the hydrostatic pressure. Figure 6 shows the pressure distribution on a wall based on linear theory.

Sainflou Method

This method is based on the second order theory of wave by Stokes (Sainflou,1928). When an incoming wave approaches, the still water level in front of structure will increase with

$$h_0 = \frac{1}{2} k H_i^2 \quad \text{coth coth } (kd) \dots \dots \dots (8)$$

where:

$h_0 [m]$ = increase of the still water level in front of wall

$d [m]$ = water depth in front of the sill

The maximum pressure at the still water level and near bed:

$$p_1 = \rho g (H_i + h_0) \dots \dots \dots (9)$$

$$p_0 = \frac{\rho g H_i}{\cosh \cosh (kd')} \dots \dots \dots (10)$$

where

$d' [m]$ = water depth above the foundation

Figure 7 shows the schematic description of the Sainflou method. The wave force can be calculated using integral of the area under the curve.

Table 2 Relevant data and result of wave force induced by the 1883 Krakatau tsunami (Method: Rule of Thumb)

ID	L (m)	H incoming (m)	H input (m)	d (m)	Wave Force (N)	Wave Force (kN)
OSD-1A	94826	2.17	4.34	4.77	303419.55	303.42
OSD-1B	131693	2.04	4.08	12.31	589721.59	589.72
OSD-3A	130694	2.08	4.16	12.62	615662.90	615.66
OSD-3B	127604	2.30	4.60	10.91	611797.78	611.80

Table 3 Relevant data and result of wave force induced by the 1883 Krakatau tsunami (Method: Linear Theory)

ID	H incoming (m)	H input (m)	d (m)	Wave Force (N)	Wave Force (kN)
OSD-1A	2.17	4.34	4.77	303419.54	303.42
OSD-1B	2.04	4.08	12.31	589721.53	589.72
OSD-3A	2.08	4.16	12.62	615662.84	615.66
OSD-3B	2.30	4.60	10.91	611797.74	611.80

To calculate the wave force, the pressure p_1 and p_0 need to be integrated with respect to the wall length (l). Mathematically speaking, the wave force is defined as

$$F = \int p \, dl \dots\dots\dots (12)$$

Since the boundary condition for length is known, Equation 13 can be further developed as

$$F = \int_{d'}^H p \, dl \dots\dots\dots (13)$$

$$F = \int_{d'}^0 p \, dl + \int_0^H p \, dl \dots\dots\dots (14)$$

Since per definition, integral is defined as the area under the curve, Equation 15 can be solved by calculating the area of trapezoid and triangle as denoted as A_1 and A_2 in Figure 15.b. Therefore,

$$F = A_1 + A_2 \dots\dots\dots (15)$$

All information and result of the calculation using this method is shown in Table 4. The result of this third method confirms the current hypothesis that OSD-1B, OSD-3A and OSD-3B are the most affected segments due to 600 kN of tsunami wave force while OSD-1A is relatively safer since the incoming wave force is only half. However, Sainflou method provides a lower estimation. The incoming wave force for OSD-1A is almost 75 kN while the rest of the segments endured roughly 150 kN of tsunami force. The estimation is about 75% lower than that of Rule of Thumb and Linear Theory. The different estimation is caused by the two different assumption used in the three methods. Both Rule of Thumb and Linear Theory are based on theory of linear wave while Stokes' second order wave theory is the foundation of Sainflou Method (Molenaar and Vorendt, 2016). The Stokes theory predict the wave behaviour more detail so the given estimation is more accurate.

The result of wave force calculation shown in Table 2, Table 3 and Table 4 is not corrected with the angle of incident wave yet. The corrected wave force is shown in Table 5 which also summarizes the calculation of all three methods. The 1883 Krakatau tsunami wave approaches all the outer sea dike segments obliquely with various angle. Only OSD-1A is approached by tsunami wave with nearly perpendicular angle while the rest of the segments have incoming wave angles that are less than 60 degree. Therefore, OSD-1A endured most of the resultant tsunami force in y-direction while tsunami force in other segments mostly dissipate in the x-direction. However, since the incoming wave force for OSD-1A is the weakest, this segment is still the least impacted outer sea dike (about 300 kN or 70 kN of force). In this, the hypothesis of OSD-1A as the least impacted outer sea dike is still stand out. However, after the incoming wave angle correction, the data clearly shows that OSD-3A is the most affected by tsunami (roughly 530 kN or 130 kN) while OSD-1B and OSD-3B are somewhere in the middle.

All these methods serve important function. Both Rule of Thumb and Linear Theory give rough estimation of tsunami wave force. Although the calculation is rough, it will be beneficial. The estimation will give safety factor for unaccounted variable such as nonlinearity due to interaction between structure and tsunami. On other hand, based on Stokes' theory, Sainflou method can predict the tsunami behaviour with structure more accurately. Therefore, using this method will be helpful to design an efficient engineering construction and consequently reduce construction cost. In the case of NCICD project, it is important to find the middle ground between design safety and efficiency of engineering design and the construction cost.

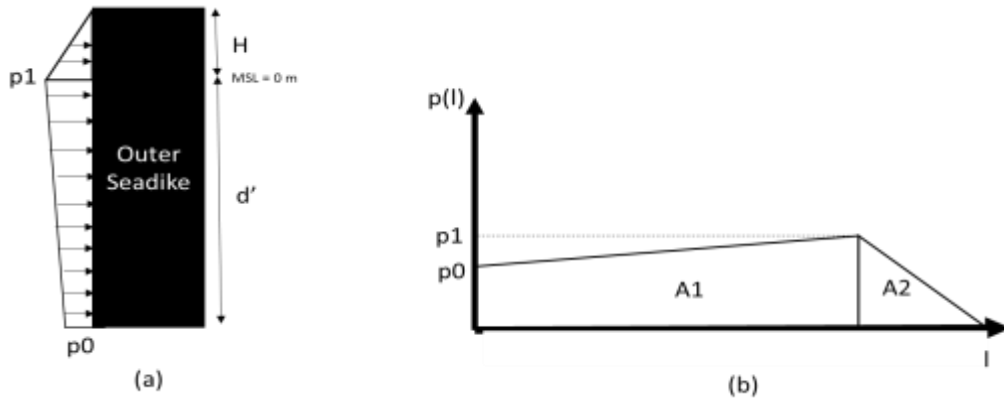

Figure 15 Vertical distribution of pressure based on Sainflou Method: (a) schematic illustration; (b) graph plot pressure vs length to illustrate the area under the curve

Table 4 Relevant data and result of wave force induced by the 1883 Krakatau tsunami (Method: Sainflou)

ID	h0 (m)	d (m)	d'(m)	p1 (N/m)	p0 (N/m)	Wave Force (N)	Wave Force (kN)
OSD-1A	0.36	6.59	4.77	25450	9.55	73476.19	73.48
OSD-1B	0.13	16.01	12.31	21853	15.70	145556.24	145.56
OSD-3A	0.15	14.54	12.62	22445	14.65	152895.52	152.90
OSD-3B	0.17	15.90	10.90	24837	18.15	147962.46	147.96

Table 5 Summary of calculated wave force after correction of incoming wave angle factor

ID	Wave angle to OSD (θ)	Wave Force (kN)		
		Rule of Thumb	Linear Theory	Sainflou
OSD-1A	88.39	303.30	303.30	73.45
OSD-1B	38.98	370.96	370.96	91.56
OSD-3A	59.63	531.18	531.18	131.91
OSD-3B	31.64	320.94	320.94	77.62

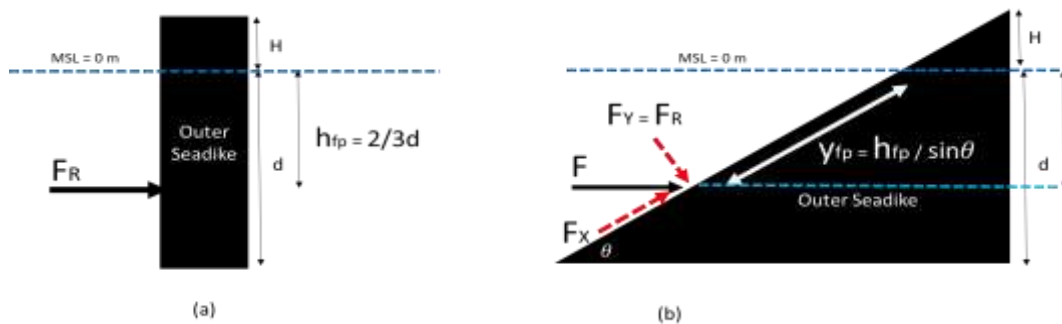

Figure 16 Illustration of the position of forcing point by the resultant wave force: (a) on a vertical wall; (b) on an inclined wall

In this study, calculation of the wave force induced by the 1883 Krakatau tsunami on the outer sea dike of NCICD is conducted with several assumption. First assumption is that the calculated wave force is uniformly distributed along the horizontal axis of the outer sea dike. In other words, the wave force in one point of the outer sea dike such as OSD-1A will be the same for the rest of OSD-1A.

Another assumption is the tsunami reflected completely by the outer sea dike. Since the geometry of the outer sea dike of NCICD is complex, it is hard to determine the reflection coefficient. Goda Method is already sophisticated enough to address this problem (Molenaar and Voreendt, 2016). However, it is limited only for short wave. Hence, the method is not applied in this study of long wave. Furthermore, it is important to note here that this empirical formula has many features. Goda Method can be used for breaking or non-breaking wave (Ito et al., 1966), designing vertical breakwater (Goda and Kakizai, 1967; Goda and Fukumori, 1972; Goda, 1974); oblique wave condition (Tanimoto et al., 1976), complex geometry of structure (Takahashi et al., 1993) and wave breaking and wave incident (Takahashi and Hosoyamada, 1994).

Even though the calculated wave force is assumed to be the same for both the vertical wall and inclined wall, the calculation need adjustment since the outer sea dike is an inclined wall. The magnitude of the force is the same but the forcing point (fp) of the resultant force will be the different. In a vertical wall, the forcing point is one third of depth with reference to the bed or two third of depth with reference to MSL (Figure 16.a). The forcing point for an inclined wall can be calculated using the slope of the outer sea dike (Figure 16.b). The forcing point (y_{fp}) for OSD-1A, OSD-1B, OSD-3A, and OSD-3B are 22.34 m, 57,65 m, 25.70 m, and 22.22 m respectively.

CONCLUSION

Mount Anak Krakatau had a latent wave force. If a tsunami happens with the same magnitude of the 1883 Krakatau tsunami, NCICD Outer Sea Dike need to be designed to anticipate such a disaster. The results of this study show that the tsunami will hit the outer sea dike with at least about 70 kN of wave force (Sainflou Method) or 330 kN (Rule of Thumb, Linear Theory). The outer sea dike defined as OSD-1A in this study is the least impacted outer sea dike (73.45 kN; 303.30 kN) while OSD-3A is the most impacted (131.91 kN; 531.91 kN).

Stoke theory-based Sainflou method can predict the non-linearity behaviour more accurately so the estimated force is smaller but more accurate. Therefore, this method is beneficial to plan efficient engineering design and as result conduct cost-effective construction. On the other hand, Rule of Thumb and Linear Theory which is built with Linear Wave theory assumption shows higher estimation. The rough estimation is also useful to accommodate unaccounted variable such as complex interaction between structure and tsunami. Therefore, the estimation will give safety factor for the engineering construction.

The calculation of wave force made in this research can be served as important design parameter for the civil engineer that is responsible for the outer sea dike construction of NCICA. However, the result of this research can be applied with the awareness of several assumption. First, the tsunami is assumed to be reflected completely by the outer sea dike. Hence, the reflection coefficient is assumed to be one. Second, the outer sea dike is assumed to be a vertical wall. The result is later adjusted to the variable of forcing point for an actual inclined wall. Third, the calculation is made for a simplified version of the outer sea dike design. Rule of thumb, Linear Theory and Sainflou Method is not designed to calculate wave force for a structure with such a complex geometry such as NCICD outer sea dike. The Goda Method is actually already improved to address this problem but the formula is only applicable for a short wave. The authors suggest a laboratory experiment to extend the Goda empirical formula to long wave application. Therefore, the interaction between tsunami and the outer sea dike of NCICD can be better understand.

ACKNOWLEDGEMENT

The idea of this study is developed after insightfull discussion with Professor Radianta Triatmadja of University of Gajah Mada. Authors wishes to acknowledge his encouragement to pursue this research idea. This study is a further work of all authors who were previously involved in state-funding research titled "Technical Recommendation for The Effect of Tsunami Wave Propagation in The Vicinity of NCICD Sea Dike due to The Volcanic Activity of Mount Krakatau". This research was funded by the state budget of Experimental Station for Coastal Engineering (*Balai Litbang Pantai*) or now known as *Balai Teknik Pantai*. The result of this research is already published in Ginting et al. (2020) and Simanjuntak et al. (2020).

REFERENCES

- Bryant, E. (2008). *Tsunami: The Underrated Hazard*. Springer: Chichester.
- Choi, B.H., Pelinovsky, E., Kim, K.O., & Lee, J.S. (2003). Simulation of the trans-oceanic tsunami propagation due to the 1883 Krakatau volcanic eruption. *Natural Hazards and Earth System Sciences vol. 3*, No. 5, 321–332. DOI: [10.5194/nhess-3-321-2003](https://doi.org/10.5194/nhess-3-321-2003)
- Francis, P. W. (1985), The origin of the 1883 Krakatau tsunamis, *J. Volcanol. Geotherm. Res.*, 25, 349–363. DOI: [10.1016/0377-0273\(85\)90021-6](https://doi.org/10.1016/0377-0273(85)90021-6).
- Ginting, J.W.R., Putra, I.A.D.R., & Simanjuntak, E.M. (2020). The effect of NCICD outer sea dike design for the occurrence of Tsunami Krakatau 1883 (in Bahasa Indonesia). *Jurnal Teknik Hidraulika Vol 11 No 1*. Bandung: PUSAIR
- Goda, Y. & Kakizai, S. (1967). Study on finite amplitude standing waves and their pressures upon a vertical wall. *Coastal Engineering in Japan*, 10, 1–11.
- Goda, Y. & Fukumori, T. (1972). Laboratory investigation of wave pressures exerted upon vertical and composite walls. *Coastal Engineering in Japan*, 15, 81–90.
- Goda, Y. (1974). A new method of wave pressure calculations for the design of composite breakwaters. *Proceeding of 14th International Conference Coastal Engineering*, 14:1702–1720.
- Ito, Y., Fujishima, M., & Kitatani, T. (1966). On the stability of breakwaters. *Coastal Engineering in Japan*, 14, 53-61.
- Latter, J. H. (1981), Tsunamis of volcanic origin: Summary of causes, with particular reference to Krakatoa, 1883, *Bull. Volcanol.*, 44, 467–490. DOI: [10.1007/BF02600578](https://doi.org/10.1007/BF02600578)
- Levin, B.W., & Mikhail A. Nosov. (2009). *Physics of Tsunami*. Berlin, Germany: Springer
- Maeno, F. & Imamura, F. (2011). Tsunami generation by a rapid entrance of pyroclastic flow into the sea during the 1883 Krakatau eruption, Indonesia. *J. Geophys. Res.* 116/B09205 DOI: [10.1029/2011JB008253](https://doi.org/10.1029/2011JB008253)
- Molenaar, WF and Vorendt, MZ. (2016). *Manual Hydraulic Structures*. Delft: TU Delft.
- Nakamura, S. (1984). A numerical tracking of the 1883 Krakatau tsunami. *Science of Tsunami Hazards*. vol. 2, 41–54.
- KOICA. (2018). *Conceptual design report of OSD*. Jakarta: Korean International Cooperation Agency
- Nomanbhoy, N., & Satake, K. (1995), Generation mechanism of tsunamis from the 1883 Krakatau eruption, *Geophys. Res. Lett.*, 22, 509–512. DOI: [10.1029/94GL03219](https://doi.org/10.1029/94GL03219).
- Project Management Unit NCICD. (2002). *Masterplan National Capital Integrated Coastal Development*. Jakarta: Ministry of Coordinator in Economic, Republic of Indonesia
- Pelinovsky, E., Choi, B.H., Stromkov, A., Didenkulova, I., & Kim, H.S. (2005). An Analysis of Tide-gauge records of the 1883 Krakatau tsunami. In K.Satake (Eds), *Tsunami: Case Studies and Recent Developments*, 57-77. Springer.
- Sainflou, M. (1928). *Essai sur les diques maritimes verticales*. Technical Report. Paris.
- Setiawan, D. (2018). Sunda Strait tsunami; Coping with loss. <https://www.jakartapost.com> (accessed April 01, 2020).
- Self, S., & Rampino, M.R. (1981). The 1883 eruption of Krakatau. *Nature*, 294, 699-704. DOI: [10.1038/294699a0](https://doi.org/10.1038/294699a0).
- Simanjuntak, E.M., Ginting, J.W.R and Putra, I.A.D.R (2020). A simple run-up calculation of Tsunami Krakatau 1883 for the evaluation of NCICD Sea dike Design. *Jurnal Teknik Hidraulika Vol 11 No 1*. Bandung: PUSAIR DOI: [10.32679/jth.v11i1.633](https://doi.org/10.32679/jth.v11i1.633)
- Symons, G.J (Ed). (1888). *The Krakatoa Eruption and Subsequent Phenomena*. Report of Krakatoa Committee. Royal Society.
- Takahashi, S. and Hosoyamada, S. (1994). Hydrodynamic characteristics of sloping top caissons. In *Proc. Int. Conf. on Hydro-Technical Eng. for Port and Harbour Construction.*, Pp. 733–746, Yokosuka, Japan. Port and Harbour Research Institute.
- Takahashi, S., Tanimoto, K., and Shimosako, K. (1993). Experimental study of impulsive pressures on composite breakwaters: Fundamental feature of impulsive pressure coefficient. *Rept of Port and Harbour Research Institute*, 31(5):33–72.
- Tanimoto, K., Moto, K., Isizuka, S., and Goda, Y. (1976). An investigation on design wave force formulae of composite-type breakwaters. *Proceedings of 23rd Japanese Conference Coastal Engineering*, Pp. 11–16.

Tehusjarana, K.M. (2018). Anak Krakatau's changing eruption pattern won't trigger tsunami: Agency. <https://www.jakartapost.com> (accessed April 01, 2020).

Triatmadja, R and Nurhasanah, A. (2012). Tsunami force on buildings with openings and protection. *Journal of Earthquake and tsunami 6 (04)*, 1250024. DOI: [10.1142/S1793431112500248](https://doi.org/10.1142/S1793431112500248)

The Jakarta Post. (2018). Warning sounded as Mt. Anak Krakatau rumbles. <https://www.jakartapost.com> (accessed April 01, 2020).

The Jakarta Post. (2019). Anak Krakatau erupts, spewing out 200-meter-high column of ash. <https://www.jakartapost.com> (accessed April 01, 2020).

USACE. (1984). *Shore Protection Manual*. Columbia: Dept. of the Army, Waterways Experiment Station, Corps of Engineers, Coastal Engineering Research Center

Verbeek, R.D.M. (1884). The Krakatoa Eruption. *Nature*, 30(757), 10–15. <https://doi.org/10.1038/030010a0>

Yokoyama, I. (1981). A geophysical interpretation of the 1883 Krakatau eruption. *J. Volcanol. Geotherm. Res.*, 9, 359–378, [doi:10.1016/0377-0273\(81\)90044-5](https://doi.org/10.1016/0377-0273(81)90044-5).

Yokoyama, I. (1987), A scenario of the 1883 Krakatau tsunami, *J. Volcanol. Geotherm. Res.*, 34, 123–132. [doi:10.1016/0377-0273\(87\)90097-7](https://doi.org/10.1016/0377-0273(87)90097-7).

Supplementary 1

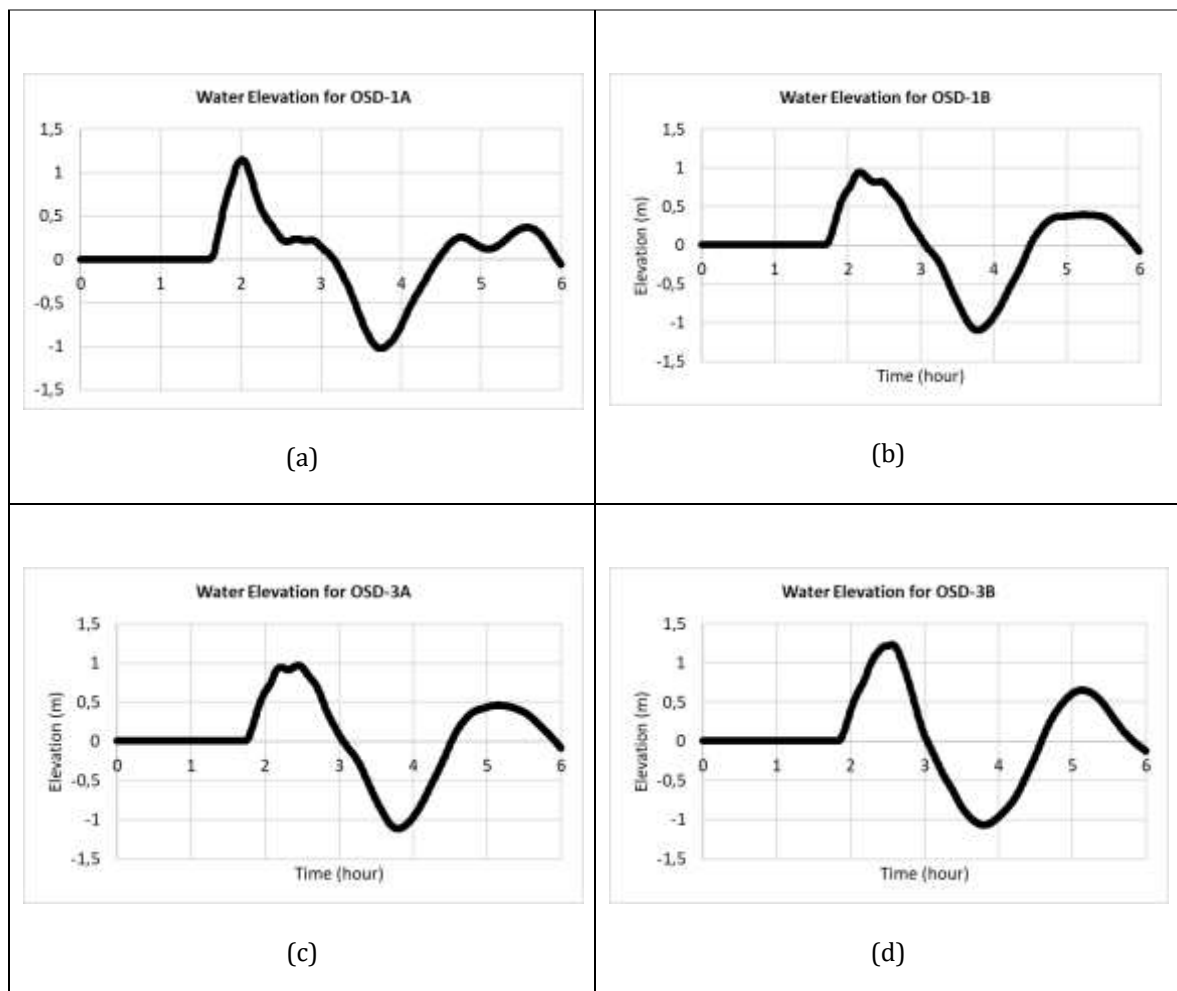

Figure S1 Water elevation time series extracted from numerical model in 4 different location of outer sea dike: (a) OSD-1A; (b) OSD-1B; (c) OSD-3A; (d) OSD-3B